

PD-series

Precision double tube linear units

Precision levels

PD-series

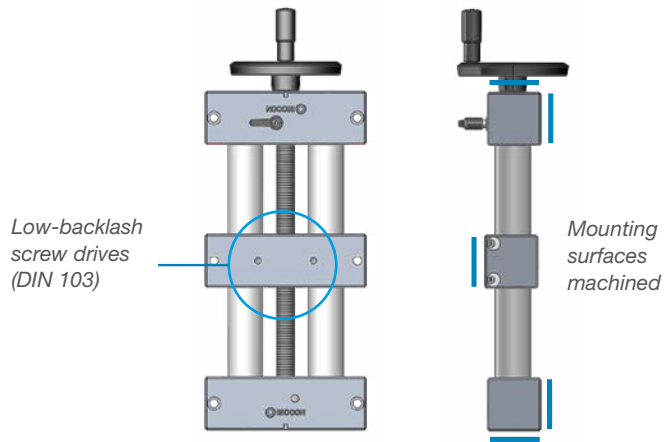
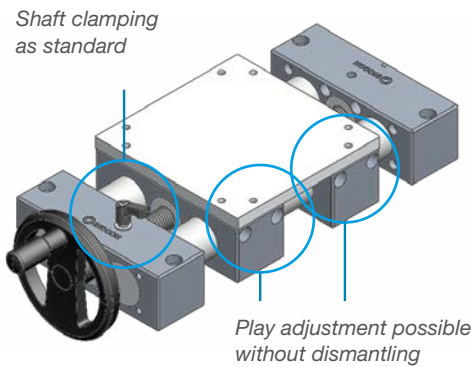

PD with chrome-plated tubes

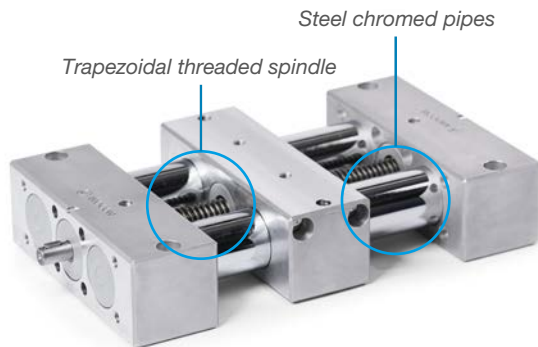

PD with hard chrome-plated solid shafts

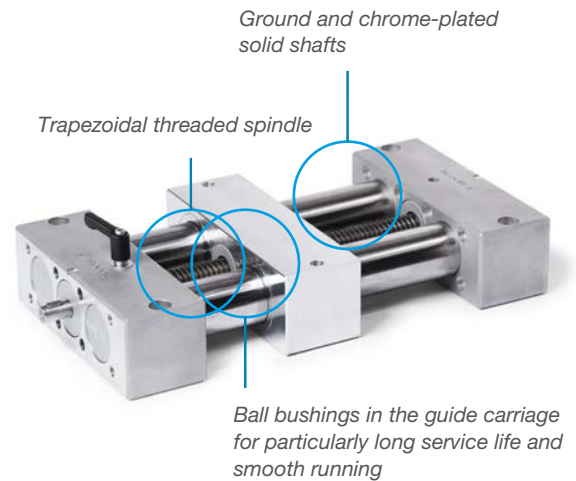

PDK with ball screw and hard chrome-plated solid shafts

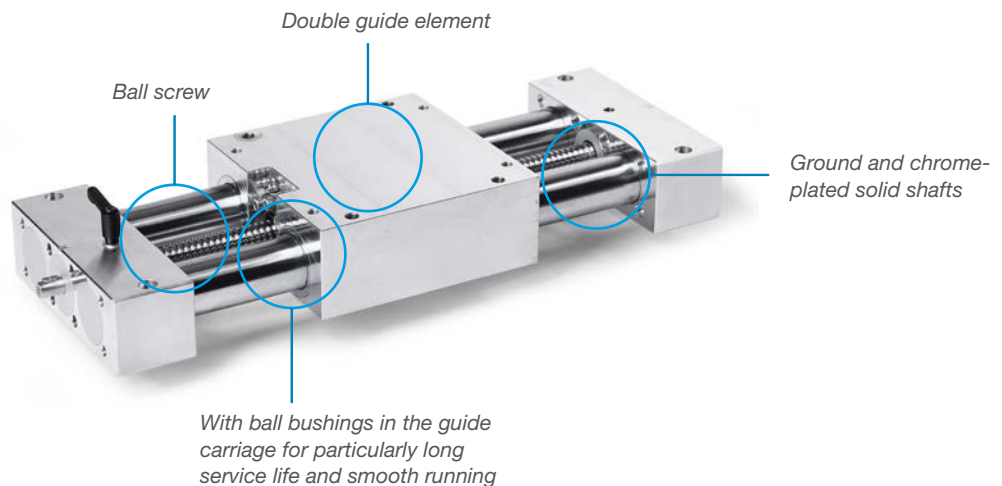

PD series

Precision double tube linear units

The new version has completely closed and machined guide and end elements for distortion-free assembly.

This is made possible by a special internal spreading technique.

Like the previous series with clamping slots, the PD series also comes with one guide element, with two opposing guide elements or with two independent guide elements, each version offered with single or double guide element (see product overview).

The selection options extend over the entire diameter program: Ø18, 30, 40, 50 and 60 mm and three precision levels can also be selected (see precision levels).

Product properties	PD series linear unit without clamping slots	VD series Linear unit with clamping slots
Distortion-free assembly	++	o
Mounting surfaces mechanically machined	++	o
Four slide bushings per slide element for optimal running clearance, each separately adjustable	++	—
Clearance adjustment possible without disassembly	++	o
Spindle clamping at end element	++	o
Constant motion sequence	++	o
Chrome-plated tubes	++	++
System distance	++	++
Mounting holes equal / compatibility connection of functional dimensions unchanged from previous design	++	++

++ very good o good — not available

Product overview

If more precise guidance is required, it is recommended to use precision double tube linear units. The round guides are fastened to the end pieces with a non-positive connection by means of tapering, resulting in higher precision.

The round guides of the precision double tube linear units are available with either chrome-plated steel or bright stainless steel precision tubes or with hard-chrome-plated and polished solid shafts.

The center spindle with ball bearings on both sides can be designed as a trapezoidal or fine thread spindle or as a recirculating ball screw. The force transmission between the recirculating ball screw and the ball screw nut takes place via rolling elements. This makes it possible to adjust the ball screw to eliminate backlash and achieve higher precision movement. The lower rolling resistance also reduces wear and the required driving force.

The guide elements have either a sliding or roller guideway.

Precision double tube linear units can be divided into three types, each available with single or double guide elements:



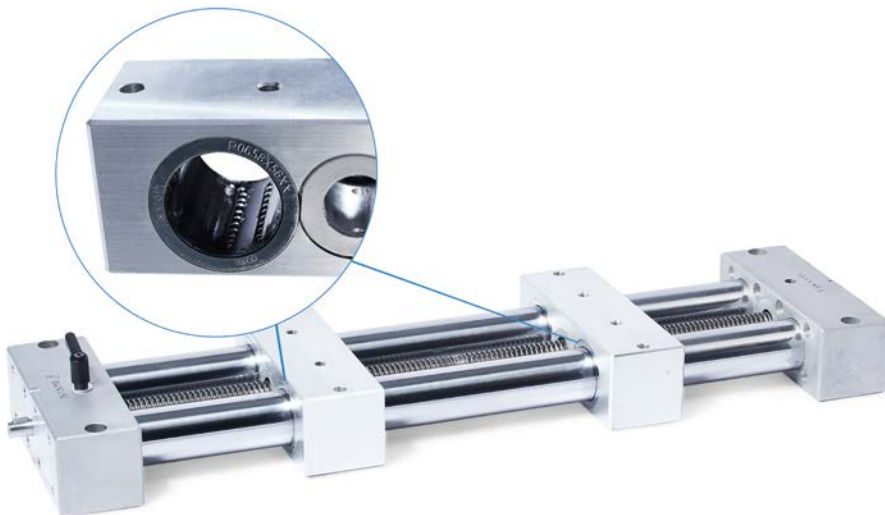



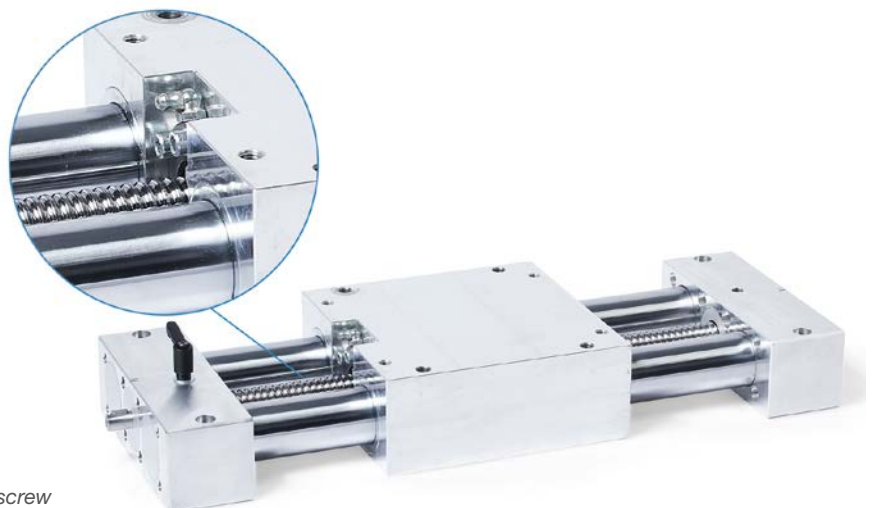

- **Linear units with one guide element:** the guide element is moved along the guide tubes by the spindle thread.
- **Linear units with two opposing guide elements:** two guide elements move symmetrically along the guide tubes due to different thread directions.
- **Linear units with two independent guide elements:** two guide elements move independently along the guide tubes due to separate spindles.



Roller slideway of the precision double tube linear units



Precision double tube linear units with recirculating ball screw

	with single guide element	with double guide element	with recirculating ball screw
Precision double tube linear units with one guide element	PD1E p. 318 	PD1D p. 322 	PD1DK p. 326 
Precision double tube linear units with two opposing guide elements	PD2E p. 330 	PD2D p. 334 	PD2DK p. 338 
Precision double tube linear units with two independent guide elements	PD3E p. 342 	PD3D p. 346 	PD3DK p. 350 

Individual customer solutions that differ from those described here can be manufactured on request.

Possible accessories for the double tube linear units include handwheels in various designs, position indicators and spacer plates for spindle clamping. The accessories are matched to the nominal diameter of the respective linear unit.

Double tube linear units can accept high forces and torques. Depending on the features, a variety of precision levels are possible, which can be flexibly adapted to many different areas of application in machine and system building, such as for height and format adjustment.

An operating manual with instructions for assembly can be downloaded from our website at inocon.de/en/service.

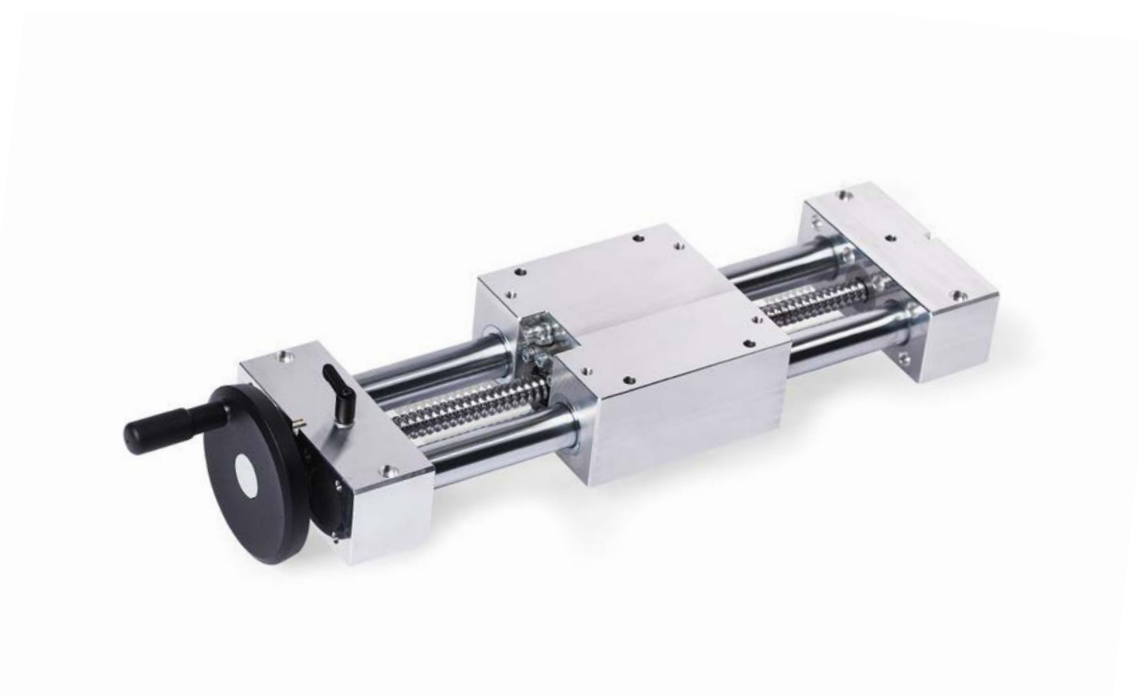



Your contact

Mr Thomas Degen

Phone +49 2226-90987-13

degen@inocon.de

**INOCON is as a manufacturer
a specialist in multi-axis
positioning systems**



INOCON GmbH
Industriestraße 31
53359 Rheinbach
Germany

Phone +49 2226-90987-0
Fax +49 2226-90987-99
verkauf@inocon.de

inocon.de