

### PRODUCT INFO

The guide tubes of the **double tube linear units VD3E** are made of chrome-plated steel or polished stainless steel precision tubes. The aluminum end pieces connect the tubes and form a solid linear guide together with the guide element. Two independent spindles with ball bearings on each side are installed in the center. The thread direction of the spindles can be chosen as desired for each side. Together with the single guide elements, the affixed spindle nuts move linearly along the spindle thread, independently of the opposite side.

Double tube linear units have high torsional stiffness and can handle high weights and torques. Depending on the design, the part to be moved is fastened to the guide element or the guide element itself is installed at the place of use such that the entire linear unit moves together.

Possible accessories are already taken into account in the selection of the linear units according to the options given in the tables. This ensures, for example, that the journal lengths  $z_1$  and  $z_2$  are appropriate for attachment of the accessories. The accessories are not included with the linear units.

### RoHS-compliant product

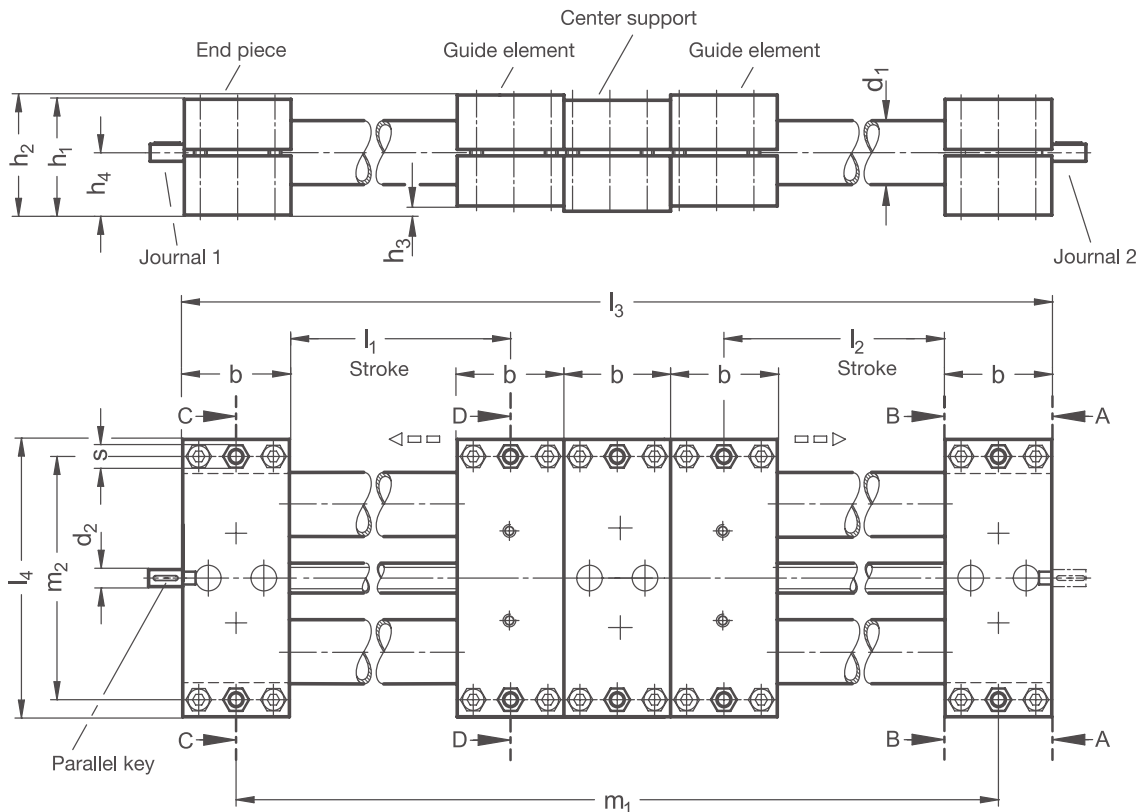

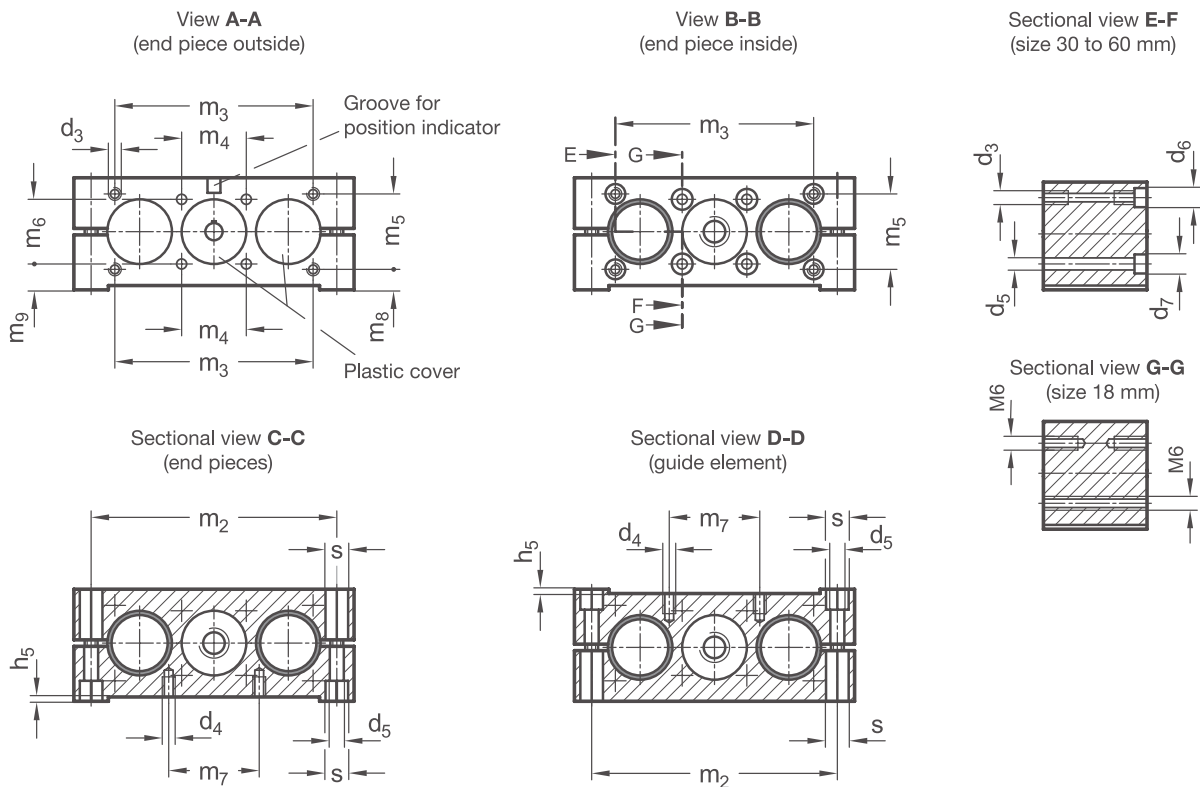

| $d_1$ | Stroke $l_1$ | Stroke $l_2$ | $b$ | $d_2$ | $d_3^*$ | $d_4^{**}$ | $d_5$ | $d_6$ | For screws<br>DIN 912 | $d_7$ | For screws<br>DIN 912 | $h_1$ |
|-------|--------------|--------------|-----|-------|---------|------------|-------|-------|-----------------------|-------|-----------------------|-------|
| 18    | ...400       | ...400       | 28  | 6     | -       | M 5        | 5,3   | -     | -                     | -     | -                     | 28    |
| 30    | ...750       | ...750       | 50  | 8     | M 6     | M 6        | 6,5   | 9     | M 5                   | 10,5  | M 6                   | 52    |
| 40    | ...1150      | ...1150      | 60  | 12    | M 8     | M 8        | 8,5   | 13,5  | M 6                   | 13,5  | M 8                   | 60    |
| 50    | ...1265      | ...1265      | 72  | 12    | M 10    | M 8        | 8,5   | 13,5  | M 8                   | 13,5  | M 8                   | 72    |
| 60    | ...1550      | ...1550      | 80  | 14    | M 10    | M 10       | 10,5  | 13,5  | M 8                   | 16,5  | M 10                  | 86    |

| $d_1$ | $h_2$ | $h_3$ | $h_4$ | $h_5$ | $l_3$         | $l_4$ | $m_1$         | $m_2$ | $m_3$ | $m_4$ | $m_5$ | $m_6$ |
|-------|-------|-------|-------|-------|---------------|-------|---------------|-------|-------|-------|-------|-------|
| 18    | 29    | 1     | 14,5  | 0,75  | $5xb+l_1+l_2$ | 81    | $4xb+l_1+l_2$ | 68    | -     | 20    | -     | 20    |
| 30    | 54    | 2     | 27    | 0,85  | $5xb+l_1+l_2$ | 130   | $4xb+l_1+l_2$ | 114   | 92    | 30    | 35    | 30    |
| 40    | 63    | 3     | 31,5  | 1,05  | $5xb+l_1+l_2$ | 180   | $4xb+l_1+l_2$ | 160   | 132   | 39    | 38    | 39    |
| 50    | 76    | 4     | 38    | 1,2   | $5xb+l_1+l_2$ | 206   | $4xb+l_1+l_2$ | 184   | 150   | 46    | 50    | 46    |
| 60    | 90    | 4     | 45    | 1,35  | $5xb+l_1+l_2$ | 240   | $4xb+l_1+l_2$ | 216   | 185   | 55    | 60    | 55    |

| $d_1$ | $m_7$ | $m_8$ | $m_9$ | $s$ | Accessories:             |                   |                   |                                       |           |     |
|-------|-------|-------|-------|-----|--------------------------|-------------------|-------------------|---------------------------------------|-----------|-----|
|       |       |       |       |     | Parallel key<br>DIN 6885 | Torque<br>support | Clamping<br>plate | Position indicator                    | Handwheel |     |
| 18    | 18    | -     | 4,5   | 8   | A2x2x12                  | VZDD              | -                 | VZPM                                  | -         | VZH |
| 30    | 42    | 9,5   | 12    | 10  | A2x2x12                  | -                 | VZK               | VZPM (only for stroke $\leq$ 1000 mm) | VZPE      | VZH |
| 40    | 62    | 12,5  | 12    | 13  | A4x4x12                  | -                 | VZK               | VZPM                                  | VZPE      | VZH |
| 50    | 62    | 13    | 15    | 13  | A4x4x12                  | -                 | VZK               | VZPM                                  | VZPE      | VZH |
| 60    | 74    | 15    | 17,5  | 17  | A5x5x16                  | -                 | VZK               | VZPM (only for trapezoidal thread)    | VZPE      | VZH |

\* usable thread depth on both sides min.  $2 \times d_3$  \*\* usable thread depth min.  $1,5 \times d_3$

Material  
**W**

|    |   |     |   |
|----|---|-----|---|
| ST | Aluminum - steel<br>• Guide tubes: Steel, chrome-plated<br>• End pieces / guide elements: Aluminum, bright. Assembly surfaces: Machined<br>• Trapezoidal / fine thread spindle: Steel, with ball bearing  | STS | Aluminum - steel<br>• Guide tubes: Steel, chrome-plated<br>• End pieces / guide elements: Aluminum, powder-coated, Black RAL 9005, Assembly surfaces: Machined bright<br>• Trapezoidal / fine thread spindle: Steel, with ball bearing  |
| ED | Aluminum - stainless steel<br>• Guide tubes: Stainless steel AISI 304, polished<br>• End pieces / guide elements: Aluminum, bright. Assembly surfaces: Machined<br>• Trapezoidal / fine thread spindle: Stainless steel AISI 303, with ball bearing | EDS | Aluminum - stainless steel<br>• Guide tubes: Stainless steel AISI 304, polished<br>• End pieces / guide elements: Aluminum, powder-coated, Black RAL 9005, Assembly surfaces: Machined bright<br>• Trapezoidal / fine thread spindle: Stainless steel AISI 303, with ball bearing |

Spindle thread direction  
**r**

|    |                   |
|----|-------------------|
| RH | Right-hand thread |
| LH | Left-hand thread  |

| $d_1$ | Spindle $\emptyset$ | Spindle pitch $p_1$ |                     | Spindle pitch $p_2$ |                     | Journal diameter $d_2$ | Journal length B $l_4$ | Journal length D $l_6$ | Journal length E $l_7$ | Journal length F $l_8$ | Individual journal length $l_9$ |
|-------|---------------------|---------------------|---------------------|---------------------|---------------------|------------------------|------------------------|------------------------|------------------------|------------------------|---------------------------------|
|       |                     | Trapezoidal thread  | Fine thread, metric | Trapezoidal thread  | Fine thread, metric |                        |                        |                        |                        |                        |                                 |
| 18    | 10                  | 3                   | 1                   | 3                   | 1                   | 6                      | 16                     | 46                     | -                      | -                      | 16...46                         |
| 30    | 14                  | 4                   | 1                   | 4                   | 1                   | 8                      | 16                     | 52                     | 31                     | 67                     | 16...67                         |
| 40    | 20                  | 4                   | 1                   | 4                   | 1                   | 12                     | 17                     | 59                     | 32                     | 74                     | 17...74                         |
| 50    | 20                  | 4                   | 1                   | 4                   | 1                   | 12                     | 18                     | 60                     | 33                     | 75                     | 18...75                         |
| 60    | 24                  | 5                   | 1,5                 | 5                   | 1,5                 | 14                     | 19                     | 61                     | 34                     | 76                     | 19...76                         |

Journal  
**Z<sub>1</sub>**

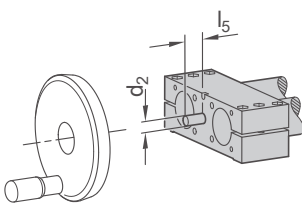
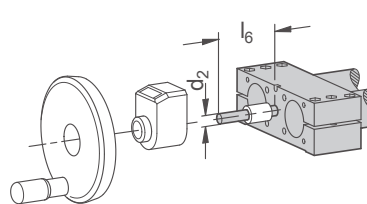
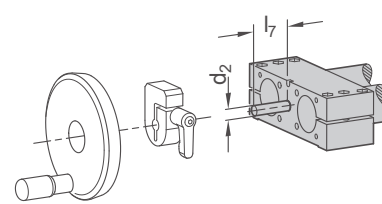
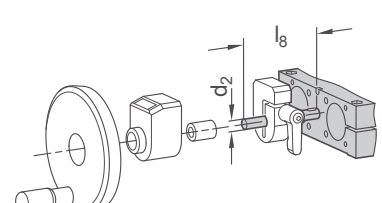
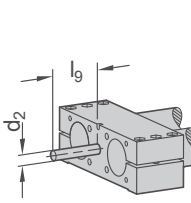
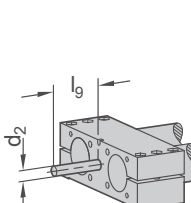
|  |  |  |  |  |  |
|--|--|--|--|--|--|
| B  | Journal for handwheel  | D  | Journal for position indicator & handwheel (torque support required for $d_1 = 18$ ) | E  | Journal for clamping plate & handwheel (only for $d_1 \geq 30$ )                   |
|  <p>Journal length <math>l_4</math></p> |  |  <p>Journal length <math>l_6</math></p> |  |  <p>Journal length <math>l_7</math></p> |  |
| F  | Journal for clamping plate, position indicator & handwheel (only for $d_1 \geq 30$ ) | Gxx  | Individual journal length with keyway (for xx, enter values from column $l_9$ )      | Hxx  | Individual journal length without keyway (for xx, enter values from column $l_9$ ) |
|  <p>Journal length <math>l_8</math></p> |  |  <p>Journal length <math>l_9</math></p> |  |  <p>Journal length <math>l_9</math></p> |  |

Journal **Z<sub>2</sub>**

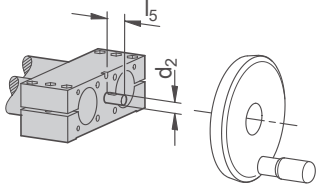
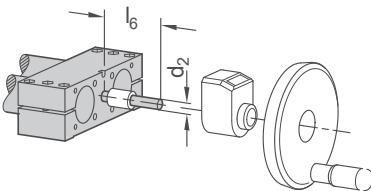
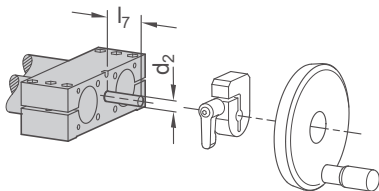
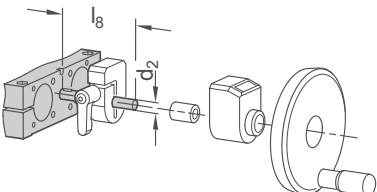
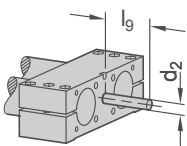
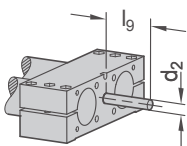
|  |  |  |
|--|--|--|
| <p><b>B</b> Journal for handwheel</p>  | <p><b>D</b> Journal for position indicator and handwheel (torque support required for <math>d_1 = 18</math>)</p>         | <p><b>E</b> Journal for clamping plate and handwheel (only for <math>d_1 \geq 30</math>)</p>                               |
|  <p>Journal length <math>l_5</math></p> |  <p>Journal length <math>l_6</math></p> |  <p>Journal length <math>l_7</math></p> |
| <p><b>F</b> Journal for clamping plate, position indicator &amp; handwheel (only for <math>d_1 \geq 30</math>)</p>       | <p><b>Gxx</b> Individual journal length with keyway (for xx, enter values from column <math>l_9</math>)</p>              | <p><b>Hxx</b> Individual journal length without keyway (for xx, enter values from column <math>l_9</math>)</p>             |
|  <p>Journal length <math>l_8</math></p> |  <p>Journal length <math>l_9</math></p> |  <p>Journal length <math>l_9</math></p> |

**ORDER KEY**

Name key | Supplemental key  
**VD3E - d<sub>1</sub> - w - l<sub>1</sub> - l<sub>2</sub> - r<sub>1</sub> - p<sub>1</sub> - z<sub>1</sub> - r<sub>2</sub> - p<sub>2</sub> - z<sub>2</sub>**

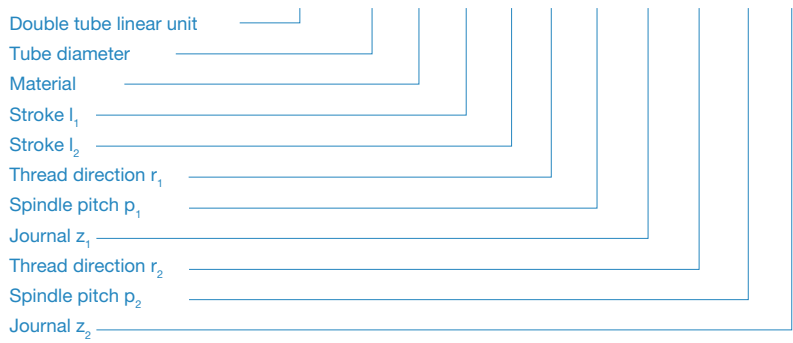

**ACCESSORIES**

- Handwheels **VZH** → see page 356
- Position indicators **VZPM / VZPE** → see page 358/360
- Clamping plates **VZK** → see page 362
- Torque supports **VZDD** → see page 368
- Angle gears **YLD** → see page 378
- Transfer units **VA** → see page 370

**ON REQUEST**

- Additional following guide elements
- Guide element connector plates
- Multiple guide elements with scissors synchronization
- Bellows covers

2D  
 2C  
 2B  
 2A  
 1D  
 1C  
 1B  
 1A